

Fuzzy logic based Coordinated Voltage Regulation Method for Distribution System with Multiple Synchronous Generators

J. D. N. Gaonkar, *Member, IEEE*, and G. N. Pillai

Abstract-- The continued interest in the distributed generation (DG) sources in recent years is leading to the growth of a number of generators connected to distribution network. One of the major concern due to connection of these generators is the rise in steady state voltage level of distribution system. Present network design practice is to limit the generator capacity to a level at which the upper voltage limit is not exceeded. This reduces the efficiency of DG system. This paper proposes a coordinated voltage control scheme using fuzzy logic based power factor controller, for distribution network with multiple synchronous generators. In the proposed scheme individual generators participate in voltage regulation of the distribution system, based on their participation factor determined using sensitivity analysis. The simulation results presented in the paper show the effectiveness of the method.

Index Terms--distributed generation, voltage control, Fuzzy logic controller, voltage reference, Fuzzy rules.

I. INTRODUCTION

In recent years there has been a considerable increase in the number of generators connected to distribution networks. Besides offering environmental benefits, integration of distributed generating units to distribution network may bring other significant benefits such as increased reliability, loss reduction, load management and also economic benefits [1]. In order to achieve these benefits with large penetration of DG sources in existing utility network, several technical problems are to be fronted such as degradation of system reliability, steady state voltage rise, increased fault level, islanding and safety issues [1, 2]. These problems are due to the design and

operating principles of the existing network. One of the major concerns is the rise in steady state voltage level of the distribution system. This is very important as distribution networks are traditionally designed to maintain customer voltage constant, within tolerance limit as dictated by statute and has always been a top priority [3]. The range of voltage level which must be maintained under different standards does not exceed $\pm 10\%$ of the normal value, with some standards being even tighter than this [2, 3]. The present practice of limiting generation capacity cannot be a solution as it leads to under utilization of DG sources.

The conventional voltage regulation methods such as online tap changing transformer associated with automatic voltage control (AVC) relay are not going to be effective in presence of a significant number of DG systems [4, 5]. Several methods like network reinforcement and constraining the generator operation to counter the voltage rise are discussed in [3]. These methods are not effective due to many reasons. A new method for determining the introduction limit, when DG unit is introduced into distribution system of which the voltage is generally controlled by LCT (load-tap changing transformer) and LDC (line drop compensation) is presented in [6]. The relation among the sending end reference voltage, power factor and capacity of DG units are used to determine the introduction limit of DG system. An attempt has been made to design an AVC relay using the artificial neural network (ANN) for voltage regulation purpose in [7]. It was found that the proposed ANN-based AVC relay has the ability to properly control the voltage magnitude of the distribution network as load changes. However using ANN-based AVC relay method needs reliable data for the training of ANN, which is not easy to obtain [7]. A flexible distributed generation (FDG) scheme in which the utility can get its requirements for improving power factor or voltage regulation and also mitigating other power quality problems has been proposed in [8]. This concept replaces the use of STATCOM and other devices for power quality problem mitigation and also reduces the cost.

Reactive power control of synchronous generators by adjusting their excitation can be very beneficial in controlling the voltage rise in cogeneration plants, diesel generator units

D. N. Gaonkar is with the Department of Electrical and Electronics Engineering, National Institute of Technology Karnataka Surathkal, Mangalore-575025 Karnataka, India (e-mail: dngaonkar@ieee.org).

G. N. Pillai is with the Department of Electrical Engineering, Indian Institute of Technology Roorkee, India-646247 (e-mail: gopinath.pillai@gmail.com).

and some mini-hydro systems. Recent developments involving mixed voltage/power factor control have shown that, by intelligently controlling the synchronous generators, voltage variations can be mitigated and reinforcement may be avoided [9]. A hybrid control algorithm for the synchronous generator based DG, that combines automatic voltage and power factor control has been presented in [10]. It is shown that it is a viable alternative to line voltage rise / drop compensation method. A fuzzy logic based automatic power factor controller is proposed in [10]. Fuzzy inference system adjusts the reference setting of the automatic power factor controller, in response to the terminal voltage. In this paper a fuzzy power factor controller applicable for multiple synchronous DG environments has been proposed. Study has been done to investigate the effectiveness of this method in regulating the steady state voltage level of a typical distribution system.

II. STEADY STATE VOLTAGE RISE

When the generator is connected to the radial feeder, its active power export reduces the power flow from the primary substation. This causes reduction in the voltage drop along the feeder. If the generator's power export is larger than the feeder load, power flows from the generator to the primary substation and this causes a voltage rise along the feeder.

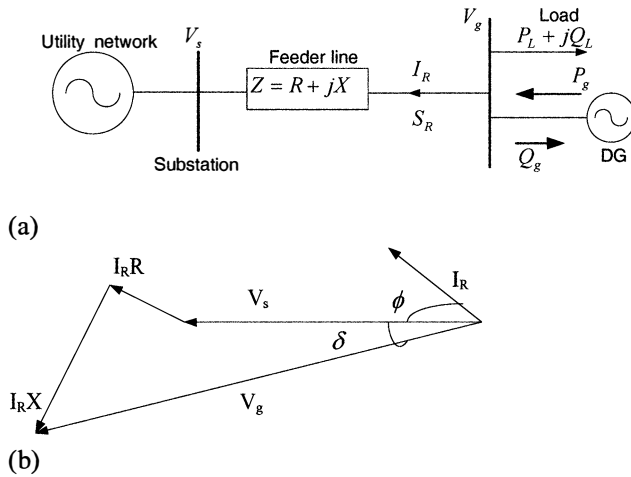

Fig. 1(a). Utility network with wind DG system (b) phasor diagram

Fig.1 (a) illustrates the connection of distributed generator to the distribution network. The active and reactive powers of the generator are P_g and Q_g respectively. P_L and Q_L represent the active and reactive power of the load connected to the distribution system. I_R is the net current through the line impedance, $Z = R + jX$ and S_R is the net power injected to network. The substation voltage and connection point voltage are V_s and V_g respectively.

$$S_R = P_R + jQ_R = (P_g + jQ_g) - (P_L + jQ_L) \quad (1)$$

$$S_R = V_g I_R^*, \quad I_R = (P_R - jQ_R) / V_g^* \quad (2)$$

$$\begin{aligned} V_g &= V_s + I_R Z = V_s + (R + jX)(P_R - jQ_R) / V_g^* \\ &= V_s + (P_R R + X Q_R) / V_g^* + j(P_R X - Q_R R) / V_g^* \end{aligned} \quad (3)$$

Considering the phasor diagram in Fig. 1(b)

$$V_g \sin \delta = (P_R X - Q_R R) / V_s \quad (4)$$

Since the voltage angle δ is very small, the term $(P_R X - Q_R R) / V_s^*$ is also very small and can be neglected. Magnitude of voltage rise ΔV is approximately given by

$$\begin{aligned} \Delta V &= (P_R R + X Q_R) / V_g \\ &= ((P_g - P_L) R + X(Q_g - Q_L)) / V_g \end{aligned} \quad (5)$$

The active power produced by embedded generators increase the voltage, whereas the reactive power can further increase or reduce it depending on the type of DG technology. The synchronous generator can generate or absorb reactive power, but the induction generator only absorbs the reactive power. These outcomes, in combination with the system's R/X ratio or distribution network characteristics and load profiles, determine whether the voltage level at the connection point is increasing by increasing the power production of DG or not.

III. FUZZY LOGIC POWER FACTOR CONTROLLER FOR SYNCHRONOUS GENERATORS

Fuzzy logic controllers are increasingly employed for a wide range of applications in electric power system. Being highly complex and nonlinear, power systems are very difficult to control with conventional methods and linearization techniques. Very often, they fail to produce a model that has the actual characteristics of the system [11, 12]. Artificial intelligence based techniques such as fuzzy logic control can overcome these difficulties. One of the important applications of fuzzy logic controller is in the excitation control of synchronous generators.

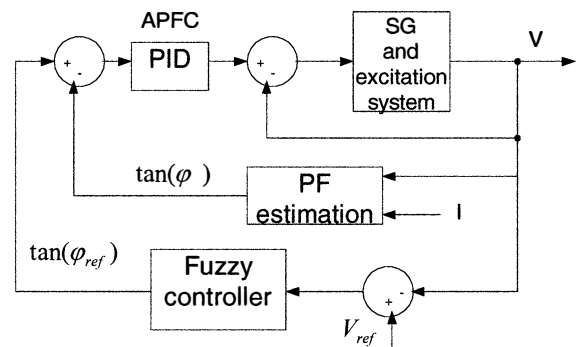
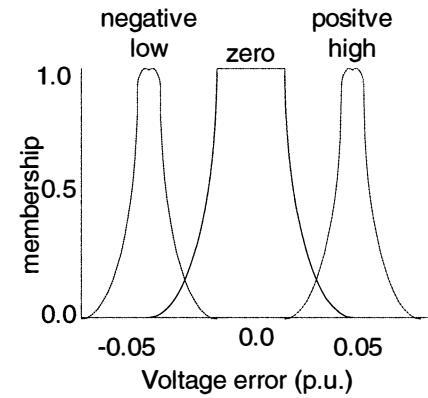

Fig. 2. Fuzzy logic power factor controller (FLPFC)

The synchronous generator system with fuzzy logic power factor controller (FLPFC) is shown in Fig 2. In this FLPFC is used to provide the reference power factor for excitation control of the synchronous generator. Presently almost all the fuzzy controllers are used and treated as black-box controllers, which when constructed properly by the trial-and-error method could produce satisfactory results.

A. Design of FLFPC

There are two major different types of fuzzy control: the Mamdani type and the Sugeno type. They mainly differ in the fuzzy control rule consequent. The Sugeno fuzzy inference system (FIS) is used in this work because the Sugeno model is suitable for generating fuzzy rules from given input-output data set in a data-driven fashion [10]. In Sugeno FIS, the final output is weighted average of each rule output; therefore; it does not require defuzzification process. Identification of desired response is necessary before designing FLC. Design of fuzzy logic power factor controller is described in this section.



(a)

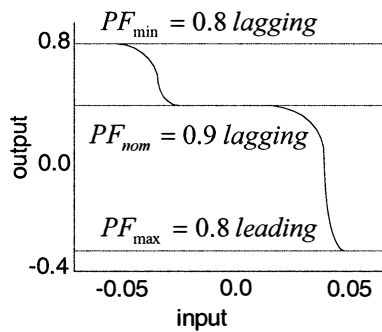

(b)

Fig. 3 (a). Input fuzzy membership functions (b) Fuzzy power factor controller output

Input stage: The fuzzy logic power factor controller used in this work is of single input single output type. The input signal is the error (ΔV) between the terminal and reference voltage. The algorithm for determination of reference voltage is described in the next section (IV) of this paper. The voltage error can vary in the range(ΔV_{max} , Zero and ΔV_{min}). Three linguistic labels define voltage error variations are; Negative high, Zero and Positive high. The input membership functions used are shown in Fig. 3 (a)

Fuzzy rules: Here, the fuzzy rules are designed based on Sugeno method of fuzzy inference. A typical rule in a Sugeno fuzzy model has the form [13].

If input = x , then, output is $Z = ax + c$.

For a zero-order Sugeno model, the output level Z is a constant ($a=0$).The zero order Sugeno model is used in this work [10]. The set of fuzzy rules are as follows

IF ($\Delta V = \text{Negative low}$), THEN $u_1 = PF_{min}$

IF ($\Delta V = 0$), THEN $u_2 = PF_{nom}$

IF ($\Delta V = \text{Positive high}$), THEN $u_3 = PF_{max}$

Output stage: One of the advantages of Sugeno model is that the output of FLC can be found using a direct formula. The final output of the system is the weighted average of all rule outputs, computed as:

$$PF_{ref} = \frac{\sum_{i=1}^3 \mu_i u_i}{\sum_{i=1}^3 \mu_i} \quad (6)$$

IV. ALGORITHM FOR DETERMINING VOLTAGE REFERENCE (V_{ref})

The input to fuzzy logic controller is generated by using the voltage error signal. The error signal is the difference between V_{ref} and the local terminal voltage. The algorithm for determination of voltage reference (V_{ref}) are given as follows

Step 1: Determine the voltages at all buses (V_{Li}) through load flow program. Check for the voltage limit violation at all buses.

$$V_{min} \leq V_{Li} \leq V_{max} \quad (7)$$

Step 2: Find out the bus for which maximum voltage violation exist among all violations

$$\max(\text{abs}(V_{Li} - V_{limit})) \quad (8)$$

Where, V_{limit} can be V_{max} or V_{min}

Step 3: Determine the control signal [14]. Supposing that the largest voltage violation happened at i^{th} , then control signal (CS) is determined as

$$CS = V_{limit} - V_{Li} \quad (9)$$

Step 4: The V_{ref} for fuzzy power factor controller shown in Fig 2, is calculated using the largest voltage violation (CS) obtained in step 3, as

$$V_{ref-j}^{new} = V_{ref-j}^{old} + M_j \times CS \quad (10)$$

Where, M_j is the participation factor determined for each generator based on the sensitivity analysis. V_{ref-j}^{new} is the new reference for j^{th} generator with $j = 1, 2, \dots, n$ where, n is the total number of generators used for control. In (10) if V_{Li} is less than V_{min} then the CS will clearly be greater than zero so that the new voltage reference will be greater than the old one. If V_{Li} is above V_{max} then the CS will clearly be less than zero. The participation factor M_j in (10) is determined by using sensitivity analysis

$$J \Delta Q_g = \Delta V \quad (11)$$

The elements of the matrix J in (11) represent $\partial V_{i1} / \partial Q_j$. Any $\partial V_{i1} / \partial Q_j$ term represents the voltage sensitivity of bus i for a change in Q -injection at bus j . The sensitivity matrix J relates the changes in reactive power generation to the change in bus voltages. To consider the reactive power generation capability, each column of matrix J is weighed by a factor whose value varies between 0 and 1. The value of 1 corresponds to the generator with maximum capability. Finally each element of the matrix J is divided by the sum of its row elements and multiplied by 100. Thus, obtaining a participation matrix whose elements indicate the relative influence of each generator in the control capability over a bus voltage [14, 15].

V. RESULTS AND DISCUSSION

The 11 kV 34 bus radial distribution system shown in Fig. 4 is used to study the performance of the proposed method. This network has 4 lateral feeders along with the main feeder and its parameters are given in [16]. It is a common practice of net work operators, that voltage at the substation end of the feeder is increased by 3% This is to overcome the voltage drop along the feeder [3] and also to keep the voltage at the end of feeder within a the limit. The voltage profile of distribution network without distributed generators is shown in Fig. 5 (a). The node voltages are within $\pm 6\%$ of the normal voltage along the feeder.

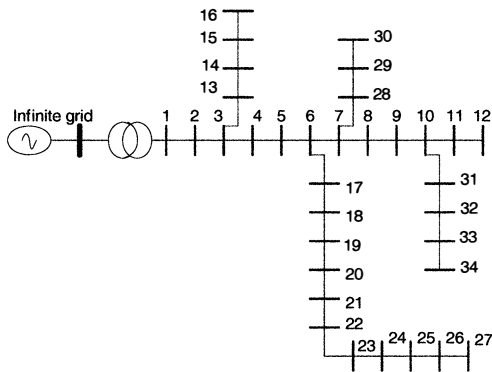
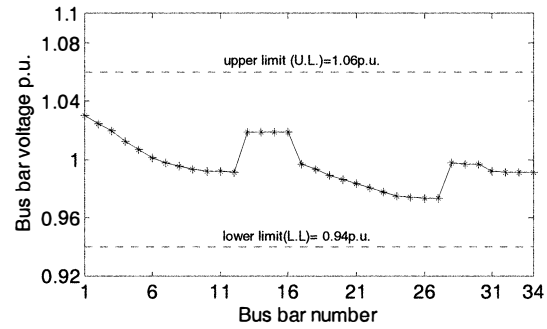

Fig. 4. 34 bus distribution network

The voltage profile of the study system with four synchronous generators with each having 2 MVA capacity, connected at 13, 23, 33 and 27th bus is shown in Fig. 5 (b). In this it can be observed that most of the bus voltages are above the upper statutory limit (1.06 p.u.). This may cause damage to customer loads connected to these buses. The Fig. 6 shows the voltage profile of the 34 bus distribution network with proposed fuzzy power factor controller for each synchronous generator.

From Fig. 6 it can be observed that the proposed coordinated method in this paper using fuzzy power factor controller shown in Fig. 2 has better performance compared to the method without co-ordination. In case if the power factor reference is determined by FLC [10] using only terminal

voltage at the individual generator without co-ordination then many of the bus voltage levels are very close to the maximum voltage limit as observed from Fig. 6.



(a)

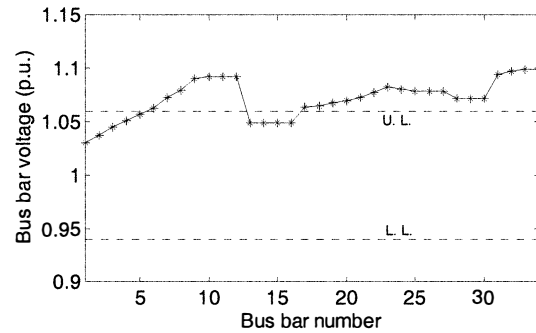

(b)

Fig. 5 (a). Voltage profile without DG (b) voltage profile with DG

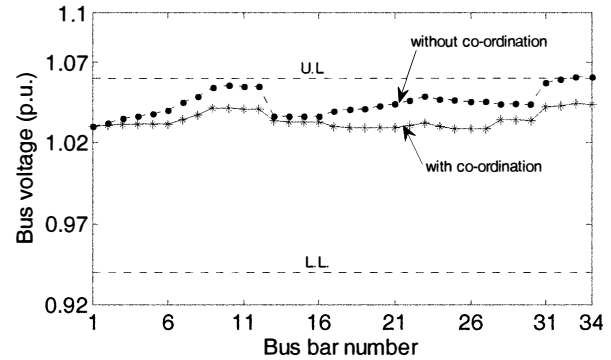

Fig. 6. Voltage profile with fuzzy power factor controller

Thus chances of customers getting disconnected due to voltage limit violation are more in the method without co-ordination. In the proposed method, individual DG systems co-ordinate in voltage regulation of distribution network through their participation factor. The participation factor for each DG system is determined from voltage sensitivity analysis and is used for obtaining reference voltage. The fuzzy logic controller determines the excitation power factor based on the error between the reference voltage and terminal voltage of the DG. It is observed from the simulation result shown in Fig. 6 that proposed method maintains the voltage profile well within the statutory limits.

VI. CONCLUSION

The steady voltage regulation in distribution system is becoming an important issue due to reverse power flow, caused by increased interconnections of DG systems. A new method for voltage regulation of distribution system with multiple synchronous generators, using fuzzy power factor controller has been proposed in this paper. In this method the participation of individual DG systems in voltage regulation is determined using voltage sensitivity based participation factor. It has been observed that the proposed method is more effective in regulating the voltage, than the control of DG based on their terminal voltage only. A case study using this method is also given. Utilization of this new method can make potential DG projects more attractive, by effective utilization of the generator capacity.

VII. REFERENCES

- [1] J. P. P. Barker and R.W. de Mello, "Determining the impact of Distributed Generation on power systems: Part I Radial distribution systems," in *Proc. IEEE Power Eng. Soc. Summer Meeting*, vol. 3, 2000, pp.1645-1656.
- [2] Ackermann and V. Knyazkin, "Interaction between distributed generation and the distribution network: Operation aspects," in *Proc. of IEEE PES Transmission & Distribution Conf. Asia-Pacific 2002*, vol. 2, pp.1357-1362.
- [3] C. L. Masters, "Voltage rise, the big issue when connecting embedded generation to long 11 kV overhead lines," *IEEE Power Eng. J.* vol. 16, issue 1, pp. 5-12, Feb. 2002.
- [4] Thomson, "Automatic voltage-control relays and embedded generation part 1," *IEEE Power Engineering J.*, vol. 14, issue 2, pp.71-76, April 2000.
- [5] C.M. Hird, H. Leite, N. Jenkins and H. Li, "Network voltage controller for distributed generation," *IEEE Proc.-Gener. Transm. Distrib.*, vol. 151, issue 2, pp.150-156, March 2004.
- [6] T.E. Kim *et al.*, "Methods of Determining the introduction Limit of Dispersed Generation Systems in A Distribution System from the Viewpoint of Voltage Regulation," *IEEE Japan, Trans.*, vol. 16-B, no.12, pp. 1461-1469, 1996.
- [7] S.K. Salman and I. M. Rida, "ANN-based AVC relay for voltage control of distribution network with and without embedded generation," in *Proc Int. Conf. on Electric Utility Deregulation and Restructuring and Power Technologies*, April 2000, pp. 263-267.
- [8] M. I. Marei, E. F. El-Saadany and M. M. A. Salama, "Flexible Distributed Generation: (FDG)" in *Proc. IEEE PES Transmission and Distribution Conf.*, vol. 1, summer 2002, pp. 49-53.

- [9] A.R.Wallace and A.E. Kiprakis, "Reduction of voltage violations from embedded generators connected to the distribution network by intelligent reactive power control," in *Proc. 5th Int. Conf. on Power System Management and Control*, 2001, pp. 210-215.
- [10] A.E. Kiprakis and A.R. Wallace, "Maximising energy capture from distributed generators in weak networks," *IEEE Proc.-Gener. Transm. Distrib.*, vol. 151, no. 5, pp. 612-618, September 2004.
- [11] P. R. Bijwe, and G. K. V. Raju, "Fuzzy distribution power flow for weakly meshed systems," *IEEE Trans. on Power Systems*, Vol. 21, no. 4, pp 1645-1652, 2006
- [12] R. H. Liang, and Y. S. Wang, "Fuzzy-based reactive power and voltage control in a distribution system," *IEEE Trans. on Power Delivery*, Vol. 18 no. 2 pp. 610-618, 2003.
- [13] T. Takagi, and M. Sugeno, "Fuzzy identification of systems and its application to modeling and control," *IEEE Trans. Syst. Man. Cybern.*, vol. 15 pp.116-132, 1985.
- [14] E. Nobile, and A. Bose, "A new scheme for voltage control in a competitive ancillary service market," in *Proc. 14th Power Systems Computation Conf.*, Sevilla, Spain, June 2002
- [15] J. L. Sancha, J. L. Fernandez, A. Cortes, and J. T. Abarca, "Secondary voltage control: analysis, solutions and results for the Spanish transmission systems," *IEEE Transactions on Power Systems*, vol. 11, no. 2, pp. 630-635, 1996.
- [16] M. M. A. Salman and A.Y. Chikhani, "A simplified network approach to the var control problem for radial distribution systems," *IEEE Transactions on Power Delivery*, Vol. 8, No. 3 pp. 1529-1535, 1993

VIII. BIOGRAPHIES

D. N. Gaonkar (M 2009) is working as an Assistant Professor, in the Department of Electrical and Electronics Engineering, National Institute of Technology Karnataka Surathkal, India. He received his Ph.D. degree from Indian Institute of Technology, Roorkee, India in the year 2008. He was a visiting scholar at the University of Saskatchewan Canada. He has published many papers in international journals / conferences. His main research interest is in the area of power system operation and control, distributed generation and power electronics.

G. N. Pillai is working as an Associate professor in the Electrical Engineering Department of Indian Institute of Technology Roorkee, India. He received his Ph.D. degree from Indian Institute of Technology, Kanpur in the year 2001. He worked as research officer at the University of Ulster, Newtownabbey U. K. and has published many papers in reputed international journals / conferences. His main research interest is in the area of power system control.